

# M-Pulse Microwave

## Silicon Bipolar MMIC Cascadable Amplifier

## MP4TD0335, MP4TD0336

### Features

- Cascadable 50Ω Gain Block
- 3dB Bandwidth: DC to 2.0 GHz
- 12.1 dB Typical Gain @ 1.0 GHz
- Unconditionally Stable ( $k > 1$ )
- Cost Effective Ceramic Microstrip Package
- Tape and Reel Packaging Available

### Description

M-Pulses's MP4TD0335 and MP4TD0336 are high performance silicon bipolar MMICs housed in a cost effective ceramic microstrip packages. The MP4TD0335 and MP4TD0336 are designed for use where a general purpose 50Ω gain block is required. Typical applications include narrow and wide band IF and RF amplifiers in industrial and military applications.

The MP4TD0335 and MP4TD0336 are fabricated using a 10 GHz  $f_T$  silicon bipolar technology that features gold metalization and IC passivation for increased performance and reliability.

### Ceramic Microstrip Case Style Outlines<sup>1,2,3</sup>

Available in short lead version as MP4TD0336.

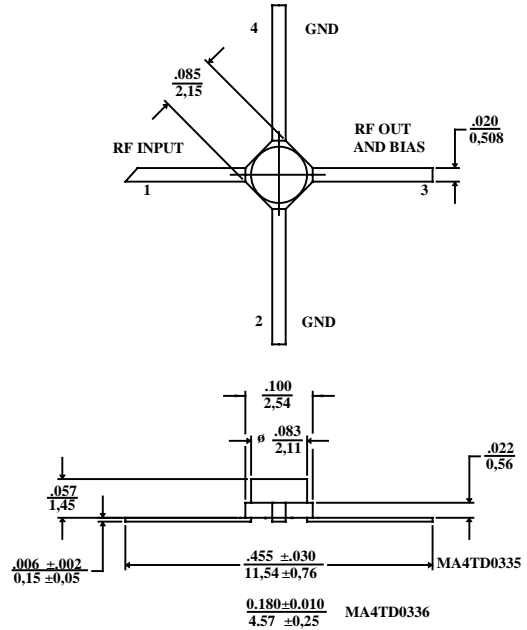

Notes: (unless otherwise specified)

1. Dimensions are in / mm
2. Tolerance: in .xxx = ±.005; mm .xx = ±.13
3. See last page of data sheet for short lead Micro-X

TYPICAL POWER GAIN vs FREQUENCY

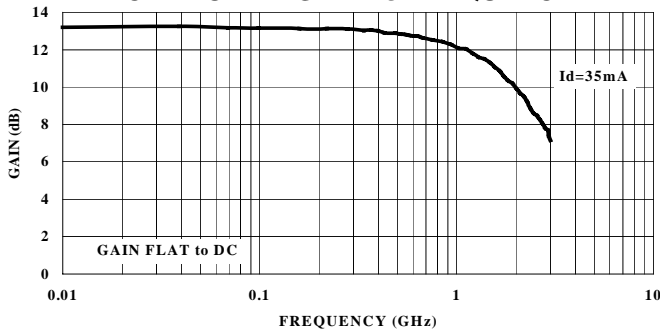

### Pin Configuration

Pin Number	Pin Description
1	RF Input
2 & 4	AC/DC Ground
3	RF Output and DC Bias

### Electrical Specifications @ $T_A = +25^\circ\text{C}$ , $I_d = 35 \text{ mA}$ , $Z_0 = 50\Omega$

Symbol	Parameters	Test Conditions	Units	Min.	Typ.	Max.
Gp	Power Gain ( $ S_{21} ^2$ )	$f = 0.1 \text{ GHz}$	dB	12.0	13.0	14.0
$\Delta G_p$	Gain Flatness	$f = 0.1 \text{ to } 1.6 \text{ GHz}$	dB	-	$\pm 0.8$	$\pm 1.1$
$f_{3dB}$	3 dB Bandwidth	-	GHz	-	2.0	-
SWR <sub>in</sub>	Input SWR	$f = 0.1 \text{ to } 3.0 \text{ GHz}$	-	-	1.6	-
SWR <sub>out</sub>	Output SWR	$f = 0.1 \text{ to } 3.0 \text{ GHz}$	-	-	1.5	-
$P_{1dB}$	Output Power @ 1dB Gain Compression	$f = 1.0 \text{ GHz}$	dBm	-	10.0	-
NF	50 Ω Noise Figure	$f = 1.0 \text{ GHz}$	dB	-	5.5	-
IP <sub>3</sub>	Third Order Intercept Point	$f = 1.0 \text{ GHz}$	dBm	-	23.0	-
$t_d$	Group Delay	$f = 1.0 \text{ GHz}$	ps	-	125	-
V <sub>d</sub>	Device Voltage	-	V	4.5	5.0	5.5
dV/dT	Device Voltage Temperature Coefficient	-	mV/°C	-	-8.0	-

Specification Subject to Change Without Notice

**Absolute Maximum Ratings<sup>1</sup>**

Parameter	Absolute Maximum
Device Current	80 mA
Power Dissipation <sup>2,3</sup>	425 mW
RF Input Power	+13 dBm
Junction Temperature	200°C
Storage Temperature	-65°C to +200°C
Thermal Resistance: $\theta_{jc} = 150^{\circ}\text{C/W}$	

1. Exceeding these limits may cause permanent damage.
2. Case Temperature ( $T_c$ ) = 25 °C.
3. Derate at 6.7 mW/°C for  $T_c > 136^{\circ}\text{C}$ .

**Typical Bias Configuration**

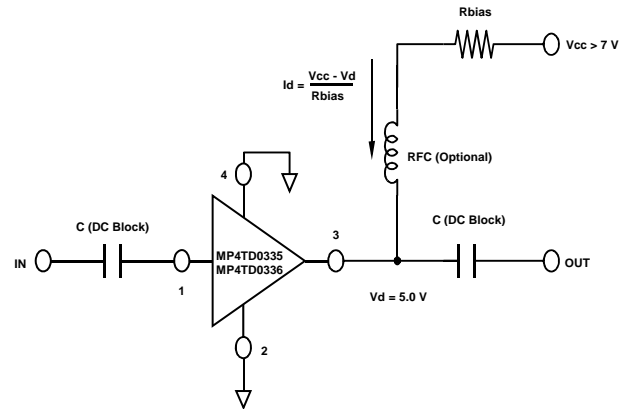

**Typical Performance Curves @  $I_d = 35\text{ mA}$ ,  $T_A = +25^{\circ}\text{C}$  (unless otherwise noted)**

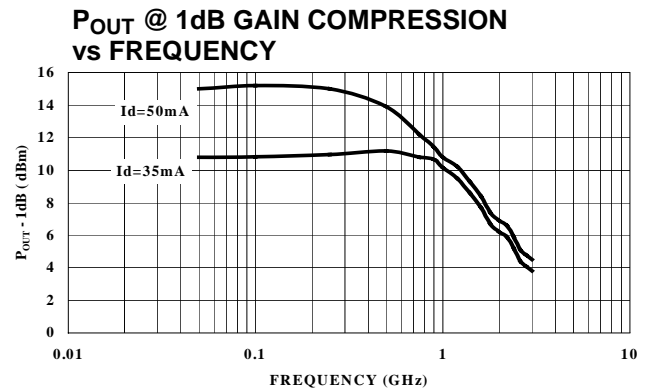
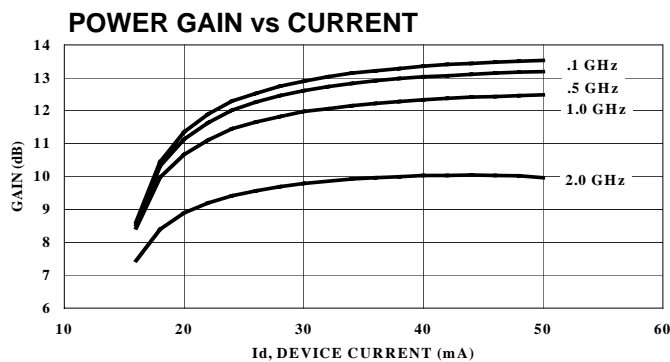
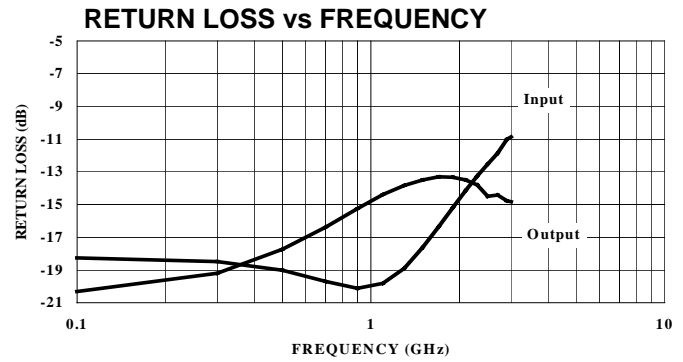
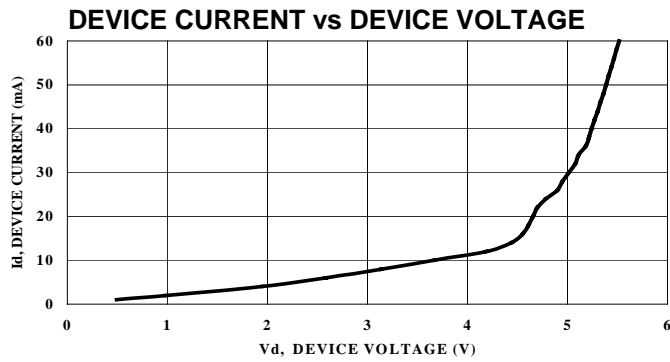

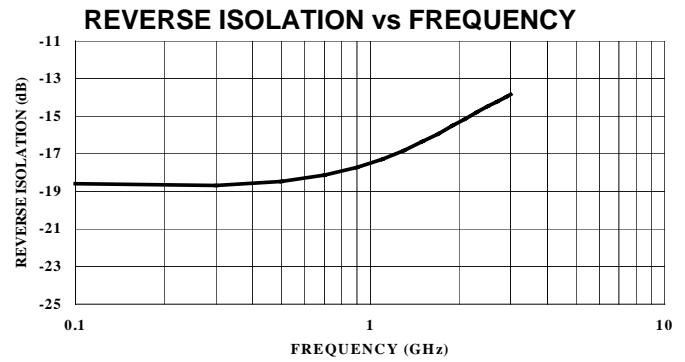
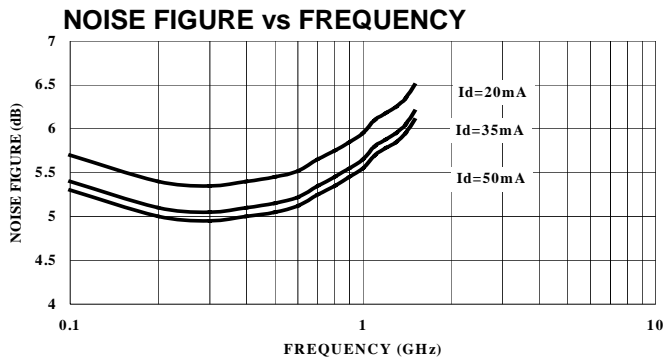

**Typical Scattering Parameters**

$Z_0 = 50\Omega$ ,  $T_A = +25^\circ\text{C}$ ,  $I_d = 35\text{ mA}$

Frequency (GHz)	S11		S21		S12		S22	
	Mag.	Angle	Mag.	Angle	Mag.	Angle	Mag	Angle
0.1	0.119	177.7	4.54	0.1	0.114	0.1	0.096	-18.4
0.2	0.118	177.8	4.52	0.1	0.114	3.2	0.102	-30.7
0.4	0.115	175.0	4.45	0.1	0.117	6.6	0.119	-57.0
0.6	0.107	175.4	4.35	0.1	0.121	9.6	0.140	-78.7
0.8	0.099	179.4	4.21	0.1	0.126	12.3	0.162	-95.7
1.0	0.099	-174.0	4.06	0.1	0.133	13.9	0.181	-110.1
1.5	0.131	-162.5	3.60	0.9	0.152	15.8	0.210	-137.3
2.0	0.184	-166.8	3.11	0.7	0.171	14.3	0.212	-156.7
2.5	0.236	-178.4	2.67	0.5	0.189	11.3	0.194	-169.0
3.0	0.287	167.1	2.31	0.3	0.203	7.7	0.180	-178.3
3.5	0.340	151.8	3.03	0.2	0.215	3.6	0.172	174.5
4.0	0.395	137.0	1.80	0.7	0.224	-0.8	0.169	167.0
4.5	0.443	123.4	1.57	-0.6	0.232	-5.3	0.177	159.2
5.0	0.480	113.0	1.39	-0.1	0.235	-9.0	0.194	152.3

**Ordering Information**

Long Lead Model No.	Short Lead Model No.	Package
MP4TD0335	MP4TD0336	Ceramic Tape and Reel
MP4TD0335T	MP4TD0336T	