

M-Pulse Microwave

Silicon Bipolar MMIC Cascadable Amplifier

MP4TD1120

Features

- High Dynamic Range Cascadable 50Ω/75Ω Gain Block
- 3dB Bandwidth: 50 MHz to 1.3 GHz
- 17.0 dBm Typical P_{1dB} @ 1.0 GHz
- 12 dB Typical Gain @ 0.5 GHz
- 3.8 dB Typical Noise Figure @ 1.0 GHz
- Hermetic Gold-BeO Microstrip Package
- The 20 package allows higher power operation

Description

M-Pulse's MP4TD1120 is a high performance silicon bipolar MMIC housed in a hermetic high reliability package. The MP4TD1120 is designed for use in 50Ω or 75Ω systems where a high dynamic range gain block is required. Typical applications include narrow and wide band IF and RF amplifiers in industrial and military applications. The 20 style package is a superior thermal dissipation package. This allows larger DC Current and the resultant improvement in output power and P_{1dB} performance than that available from the packages for this chip.

The MP4TD1120 is fabricated using a 10 GHz f_T silicon bipolar technology that features gold metalization and IC passivation for increased performance and reliability.

Gold-BeO Microstrip Package Outline^{1,2}

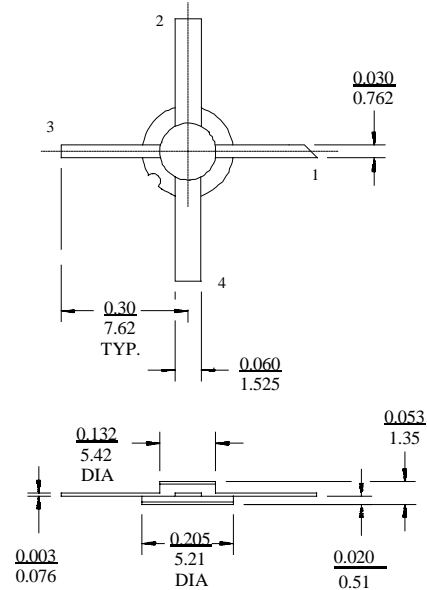

Notes: (unless otherwise specified)

1. Dimensions are in / mm

2. Tolerance: in .xxx = ±.005; mm .xx = ±.13

TYPICAL POWER GAIN vs FREQUENCY

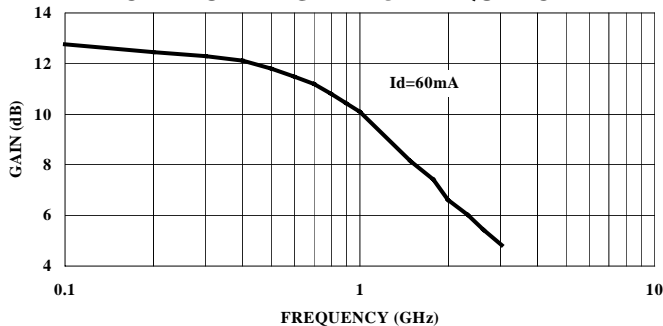

Pin Configuration

Pin Number	Pin Description
1	RF Input
2 & 4	AC/DC Ground
3	RF Output and DC Bias

Ordering Information

Model No.	Package
MP4TD1120	BeO Ceramic

Electrical Specifications @ T_A = +25°C, I_D = 60 mA, Z₀ = 50Ω

Symbol	Parameters	Test Conditions	Units	Min.	Typ.	Max.
G _p	Power Gain (S ₂₁ ²)	f = 0.1 GHz	dB	11.5	12.5	13.5
ΔG _p	Gain Flatness	f = 0.1 to 0.7 GHz	dB	-	±0.8	±1.0
f _{3 dB}	3 dB Bandwidth	ref 50 MHz Gain	GHz	-	1.3	-
SWR _{in}	Input SWR	f = 0.1 to 1.0 GHz	-	-	1.9	-
SWR _{out}	Output SWR	f = 0.1 to 1.0 GHz	-	-	2.1	-
P _{1 dB}	Output Power @ 1 dB Gain Compression	f = 1.0 GHz	dBm	-16.0	17.0	-
NF	50 Ω Noise Figure	f = 1.0 GHz	dB	-	3.8	-4.5
IP ₃	Third Order Intercept Point	f = 1.0 GHz	dBm	-	30.0	-
t _D	Group Delay	f = 1.0 GHz	ps	-	160	-
V _d	Device Voltage	-	V	4.5	5.5	6.5
dV/dT	Device Voltage Temperature Coefficient	-	mV/°C	-	-8.0	-

Specification Subject to Change Without Notice

Absolute Maximum Ratings¹

Parameter	Absolute Maximum
Device Current	90 mA
Power Dissipation ^{2,3}	560 mW
RF Input Power	+20 dBm
Junction Temperature	200°C
Storage Temperature	-65°C to +200°C
Thermal Resistance: $\theta_{jC} = 135^{\circ}\text{C/W}$	

1. Exceeding these limits may cause permanent damage.
2. Case Temperature (T_c) = 25 °C.
3. Derate at 7.4 mW/°C for $T_c > 124^{\circ}\text{C}$.

Typical Bias Configuration

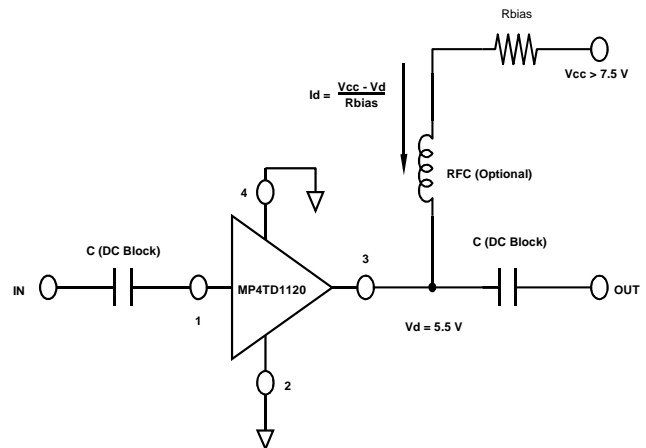

Typical Performance Curves @ $I_d = 60\text{ mA}$, $T_A = +25^{\circ}\text{C}$ (unless otherwise noted)

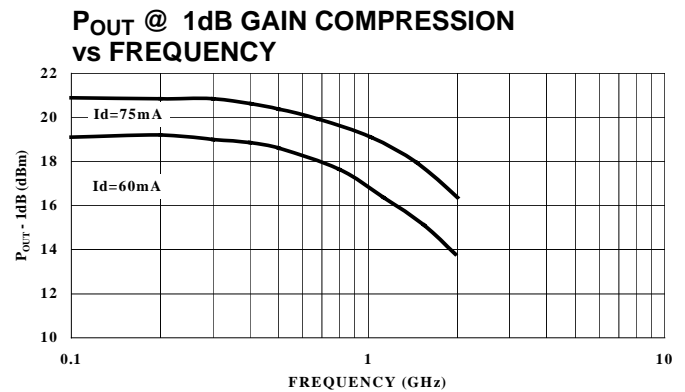
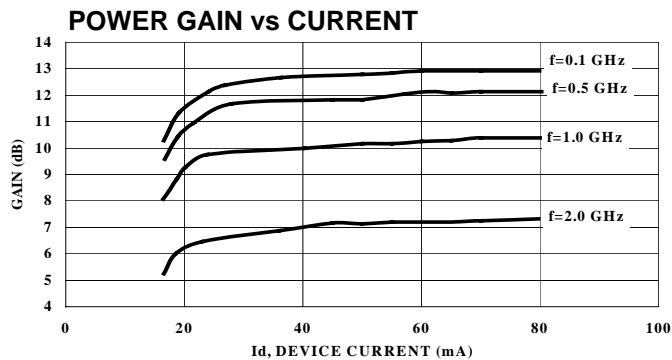
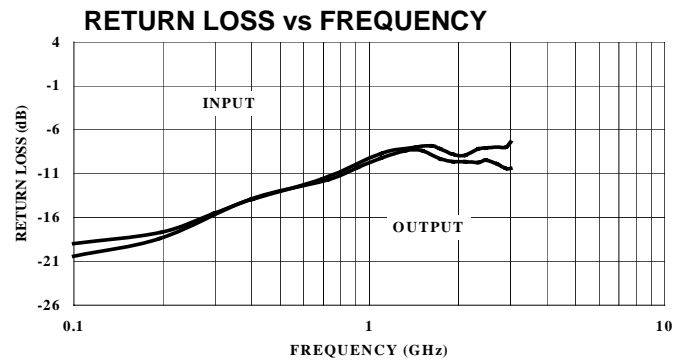
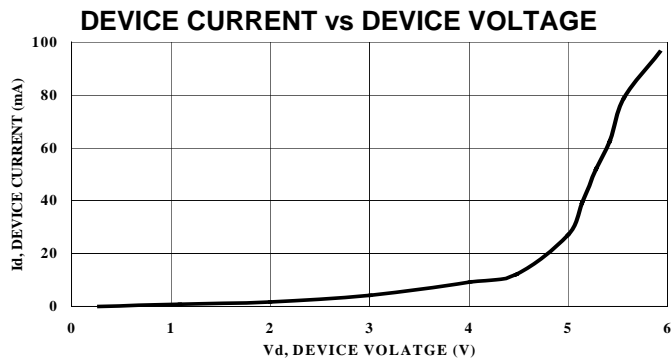

Specification Subject to Change Without Notice

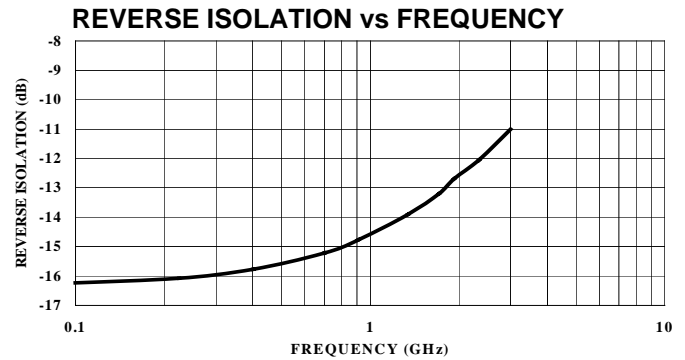
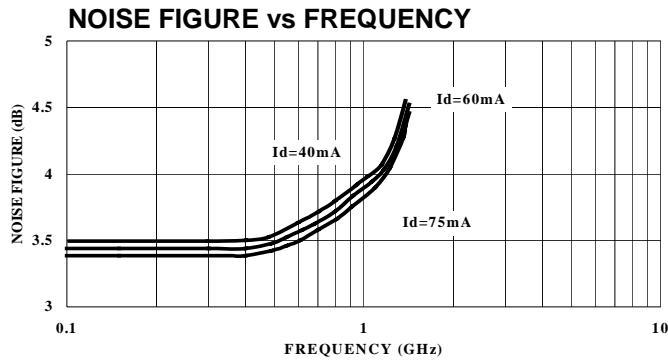

Typical Scattering Parameters

$Z_0 = 50\Omega$, $T_A = +25^\circ\text{C}$, $I_d = 60\text{ mA}$

Frequency (GHz)	S11		S21		S12		S22	
	Mag.	Angle	Mag.	Angle	Mag.	Angle	Mag	Angle
0.1	0.112	-124.0	4.41	167.1	0.151	6.1	0.10	-117.0
0.2	0.129	-127.6	4.31	161.5	0.155	6.8	0.12	-122.0
0.3	0.158	-128.3	4.20	154.7	0.157	8.9	0.16	-123.6
0.4	0.192	-129.6	4.08	147.8	0.161	10.7	0.19	-126.3
0.5	0.221	-131.8	3.94	141.1	0.165	11.9	0.22	-130.2
0.6	0.247	-134.4	3.79	134.7	0.170	13.7	0.25	-133.7
0.7	0.269	-137.7	3.62	128.6	0.174	14.7	0.27	-137.6
0.8	0.286	-140.3	3.46	123.2	0.178	15.5	0.29	-141.8
0.9	0.302	-143.4	3.32	118.0	0.182	17.1	0.31	-146.1
1.0	0.311	-146.5	3.19	113.2	0.188	18.0	0.32	-150.1
1.1	0.324	-150.1	3.07	108.3	0.194	18.2	0.33	-154.0
1.2	0.335	-153.6	2.93	103.7	0.198	18.0	0.34	-157.1
1.3	0.346	-156.1	2.81	99.3	0.202	18.7	0.35	-159.9
1.4	0.357	-158.1	2.70	95.0	0.207	18.7	0.36	-162.3
1.5	0.361	-160.3	2.59	91.5	0.211	19.1	0.36	-164.8
1.6	0.360	-162.3	2.50	88.0	0.214	19.6	0.35	-167.0
1.7	0.363	-163.6	2.44	85.0	0.220	19.7	0.35	-168.6
1.8	0.361	-165.9	2.38	81.5	0.227	20.3	0.35	-171.5
1.9	0.360	-168.2	2.31	78.1	0.232	20.1	0.34	-173.7
2.0	0.359	-171.2	2.25	75.2	0.234	20.2	0.34	-176.9
2.1	0.358	-174.2	2.17	72.7	0.238	20.3	0.34	-179.4
2.2	0.362	-177.5	2.12	70.3	0.240	20.7	0.34	178.1
2.3	0.366	179.3	2.07	67.6	0.246	20.3	0.34	176.4
2.4	0.373	177.0	2.02	65.3	0.248	20.6	0.34	174.4
2.5	0.376	174.2	1.97	62.5	0.257	20.0	0.34	174.7
2.6	0.381	172.8	1.94	59.5	0.264	19.3	0.37	173.4
2.7	0.383	171.0	1.91	56.7	0.268	19.7	0.33	172.2
2.8	0.385	169.2	1.86	54.1	0.272	18.2	0.32	171.6
2.9	0.390	167.0	1.82	52.5	0.273	18.8	0.31	169.0
3.0	0.396	164.1	1.82	50.7	0.282	18.8	0.31	167.3

Specification Subject to Change Without Notice